



# **OWL CAMERA SERIES**

## **CAM/CMOS-2K.LS**

### **ULTRA-HIGH PERFORMANCE**

### ***Line Scan Camera***



## **Camera User's Manual**

### **Models RDI & MRDI**



## EMC Conformance

This equipment has been tested and found to comply with the limits for a Class A digital device, pursuant to Part 15 of the FCC Rules.

This product fulfills the following requirements of the standards and carries the CE marking.

EMC:       FCC Part 15, Subpart B  
              EN 6100-6-4:2001  
              EN 6100-6-2:2001  
              EN6100-3-2:2000  
              EN 6100-3-3:1995/A1:2001

# FAIRCHILD IMAGING OWL CAMERA SERIES USERS MANUAL

The CAM/CMOS-2K.LS Line Scan Camera

Rev B

© 2004 Fairchild Imaging, Inc.

Fairchild Imaging, Inc.  
1801 McCarthy Blvd.  
Milpitas CA 95035 USA  
1-800-325-6975  
[www.fairchildimaging.com](http://www.fairchildimaging.com)

## PRELIMINARY DOCUMENT

The information in this manual is preliminary.

All information provided in this manual is believed to be correct at the time of writing. No responsibility is assumed by Fairchild Imaging for its use. Fairchild Imaging intends to make this manual as accurate as possible and reserves the right to make changes to this information without notice.

## Terminology

Every effort has been made in this manual to use standard, consistent definitions. In particular, the following terminology has been adopted:

- *Configuration* refers to CameraLink™ setup including choice of Base, Dual Base or Medium; one or two PCs; transmitted data path width, etc.
- *Mode* refers to synchronization control; i.e., Freerunning, ExSynch, etc.
- *Parameter* refers to user-settable variables such as exposure (integration) time, line rate, etc.
- *Environment* refers to the entire collection of user-settable items: configuration, mode, parameters, image/test pattern, etc.

# Table of Contents

## SECTION 1

### Introduction to the CAM/CMOS-2K.LS

Ultra-High Performance Line Scan Camera .....	6
---	---

1.1 Camera Highlights.....	6
1.2 Camera Specification: RDI and MRDI Performance Specification .....	7
1.3 Thermal Considerations .....	8
1.4 Image Sensor.....	9

## SECTION 2

Camera Hardware Interface.....	11
--------------------------------	----

2.1 Installation Overview .....	11
2.2 Connectors, Pinouts and Cables .....	11
2.3 Power Supply .....	12
2.4 LED Indicator Status Lamp .....	13

## SECTION 3

Camera Control .....	14
----------------------	----

3.1 Quick Start with the Camera Link™ Interface .....	14
3.2 Commands.....	14
3.3 Camera Command Summary.....	18
3.4 The Four Modes for Synchronizing with the CAM/CMOS-2K.LS .....	19

## SECTION 4

Mechanical and Optical Guidance .....	26
---------------------------------------	----

4.1 Camera Dimensions and Mounting Facilities .....	26
4.2 Lensing.....	27
4.3 Lens Mount Extender Tube .....	27
4.4 Mechanical Drawing of Available Camera Face Mounting “L” Bracket.....	29
4.5 Lenses.....	30
4.6 Positioning Accuracy of the Sensor Chip in the Camera .....	30
4.7 Illumination .....	30
4.8 Light Sources .....	30
4.9 Lens Modeling.....	31

**SECTION 5**  
**Handling Instructions .....32**

5.1 Electrostatic Discharge.....32  
5.2 Preventing ESD Damage .....32  
5.3 Protecting Against Dust, Oil and Scratches.....32  
5.4 Cleaning the Sensor Window .....32

**SECTION 6**  
**Troubleshooting.....33**

6.1 Check the Obvious Things First .....33  
6.2 Use the Camera Control Interface to Perform Checks .....33  
6.3 Other Areas You Should Check .....33

**SECTION 7**  
**Product Support.....35**

**REFERENCE A**  
**Camera Link™ Introduction .....36**

## SECTION 1

# Introduction to the CAM/CMOS-2K.LS Ultra-High Performance Line Scan Camera

## 1.1 Camera Highlights

### Description

The OWL CMOS Line Scan Camera is an ultra-sensitive camera for use in line scan applications that demand high performance under low light conditions. The camera is based upon a 2K CMOS linear sensor that utilizes an active reset technology to obtain high performance in low light applications while operating at very high data rates. Two versions of this camera are available.

**RDI (Read During Integration)** mode runs at line rates up to 38 KHz. Read noise for this version is  $\sim 9e^-$  ( $< 5.7\text{DN}$  in 12 bit data).

**MRDI (Multiple Read During Integrate)** mode has a maximum read noise of  $0.4e^-$  at a maximum line rate of 2.9KHz.

The CMOS linear sensor that is used in this camera has a unique feature that allows gain selectability at the pixel level. The gain of each pixel can be switched between high or low gain. In the high gain mode, the noise is minimized, while in the low gain mode, the dynamic range is maximized.

The 12-bit output of this camera line utilizes CameraLink and will provide data at 80 MHz (40 MHz per output). The camera offers features such as anti-blooming and programmable gain and offset.

It is packaged in a very compacted and rugged housing that contains a standard M58 x 0.75 base lens thread. Optional (Nikon F or C Mount) lens adapters are available.

### Programmability

- Simple menu-based configuration for selection of gain, calibration, test patterns operational control, and diagnostics.
- CameraLink™ camera-PC communications.

### Usability

- Programmable gain, offsets, and controls
- Internal flat field correction
- Easy integration “plug compatible” Camera Link™ interface
- Exposure control

## Full Spectrum of Applications

- Precision manufacturing inspection
- Web inspection
- Sorting and routing
- Biomedical readout systems
- Diagnostic systems

## 1.2 Camera Specification: RDI and MRDI Performance Specification

Table 1.2.1

Functions	RDI	MRDI
<b>Data rates</b>	Up to 80 MHz	Up to 80 MHz
<b>Line rates</b>	38 KHz	2.9 KHz
<b>Dynamic Range</b>	High gain 650:1 Low gain 1100:1	High gain 10,000:1 Low gain 31,000:1
<b>Resolution</b>	2048 pixels	2048 pixels
<b>Pixel size</b>	7 $\mu$ m x 7 $\mu$ m	7 $\mu$ m x 7 $\mu$ m
<b>Max Clock speed</b>	80 MHz	80 MHz
<b>Max Pixel Clock per Output</b>	40 MHz	40 MHz
<b>Anti Blooming</b>	15000 X	15000 X
<b>Digitized (ADC) Output</b>	12 bits	12 bits
<b>Pixel gain selectable pixel-by-pixel</b>	1X or 8.5X	1X or 8.5X
<b>Output Gain Range</b>	18 dB	18 dB
<b>External Synchronization</b>	Option available	Option available
<b>Random Noise (pk-pk) rms*</b>	44DN pk-pk, 6DN RMS	3DN pk-pk, 0.4DN RMS
<b>Noise Equivalent Exposure</b>	9.7 pJ/CM <sup>2</sup> *	.7 pJ/CM <sup>2</sup>
<b>Sat. Equivalent Exposure</b>	5 nJ/CM <sup>2</sup> * 40 nJ/CM <sup>2</sup> **	5 nJ/CM <sup>2</sup> 40 nJ/CM <sup>2</sup> **
<b>Intuitive command-control instruction set</b>	See Section 3.2	See Section 3.2
<b>Sensitivity: High gain Low gain</b>	>700 DN/nJ/cm <sup>2</sup> 61.5 DN/nJ/cm <sup>2</sup>	>700 DN/nJ/cm <sup>2</sup> 61.5 DN/nJ/cm <sup>2</sup>
<b>Flat field correction</b>	Internal	Internal
<b>Lens mount type</b>	M58 to Nikon F-mount & C – mount	M58 to Nikon F-mount & C-mount
<b>Body Size (W H D)</b>	3.92" W x 3.92"H x 1.84 D	3.92" W x 3.92"H x 1.84 D
<b>Power Supply</b>	5.0V	5.0V
<b>Power Dissipation</b>	2.5W	2.5W
<b>Ambient Operating Temp</b>	0 to 45° C	0 to 45° C
<b>Storage Temp</b>	0 to 75° C	0 to 75° C
<b>Power Connector</b>	4 – pin Hirose HR10A-7R-4P	4 – pin Hirose HR10A-7R-4P
<b>Data Connector</b>	MDR-26 CameraLink™ config. Single Base One 3m 10226-6212VC	MDR-26 CameraLink™ config. Single Base One 3m 10226-6212VC
<b>Control connector</b>	CameraLink™ Connectors	CameraLink™ Connectors

\*At High Gain \*\* At Low Gain

Table 1.2.2

Settings and Controls			
Function	Factory Calibrated	User Settable	Camera Link
Reset to Default Conditions		X	X
Fixed Pattern Noise Correction	X	X	X
PRNU Correction		X	X
Integration Time		X	X
External Synch / Free Run		X	X
Pixel Level Gain		X	X
Line Synchronization		X	X
Test Patterns	X	X	X

### 1.3 Thermal Considerations

The CAM/CMOS 2K.LS has been carefully designed to separate the camera electronics from the image sensor. In addition, the Fairchild Imaging CMOS sensor runs cooler than a CCD device.



***Fairchild Imaging advises waiting until the camera has stabilized thermally before performing offset and gain corrections. You can determine that the camera has stabilized thermally by repeatedly using the "TSB" command to read sensor temperature. When sensor temperature changes less than 0.1 °C per minute, the camera has stabilized.***



***Try to avoid excess temperatures in the ambient around the camera.***



**Figure 1.3.1**  
**RDI and MRDI Responsivity Curve**

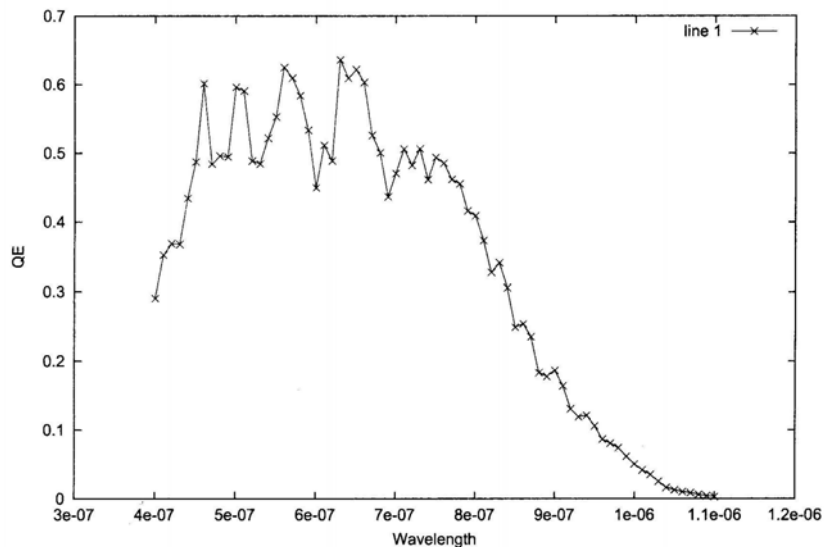

#### 1.4 Image Sensor

Pixel level processing image sensors are based on the principle that photons induced by charge at the pixel site should be converted to, as nearly as possible, a noise-free signal at the pixel site. The application of this principle produces the lowest possible noise and also allows signal control at each pixel.

As is true in other sensors, photons induce charge which is collected on a capacitor at the photo site. In a pixel level processing sensor, this charge is converted to an amplified voltage at the pixel. This voltage is then read out through a multiplexor to an external circuit. Since the readout starts with a strong signal, the dominant read noise source is the noise associated with the charge accumulation at the pixel.

The 2048 x 1 linear CMOS image sensor uses a low fixed pattern noise capacitive transimpedance amplifier (LFPN CTIA) pixel architecture. The pixel also includes circuitry for reducing 1/f noise, correlated double sampling, electronic shuttering, and a horizontal anti-blooming drain. High speed non-destructive readout of the sensor is achieved by using a hierarchical readout structure with two output ports.

In simplified form, the pixel integration cycle consists of three steps: 1) reset the capacitor to fully charged, 2) accumulate electrons on the capacitor, and 3) read the resulting charge value. Conventionally these steps have been done by sensor-wide controls. Use of pixel level processing results in at least an order of magnitude reduction in noise due to the reset step as well as noise reduction in the multiplexing of the pixel values and the noise due to amplification for off chip drive.

Shown on the following page is a block diagram of the Fairchild Imaging 2048 x 1 CMOS sensor.

Figure 1.4.1

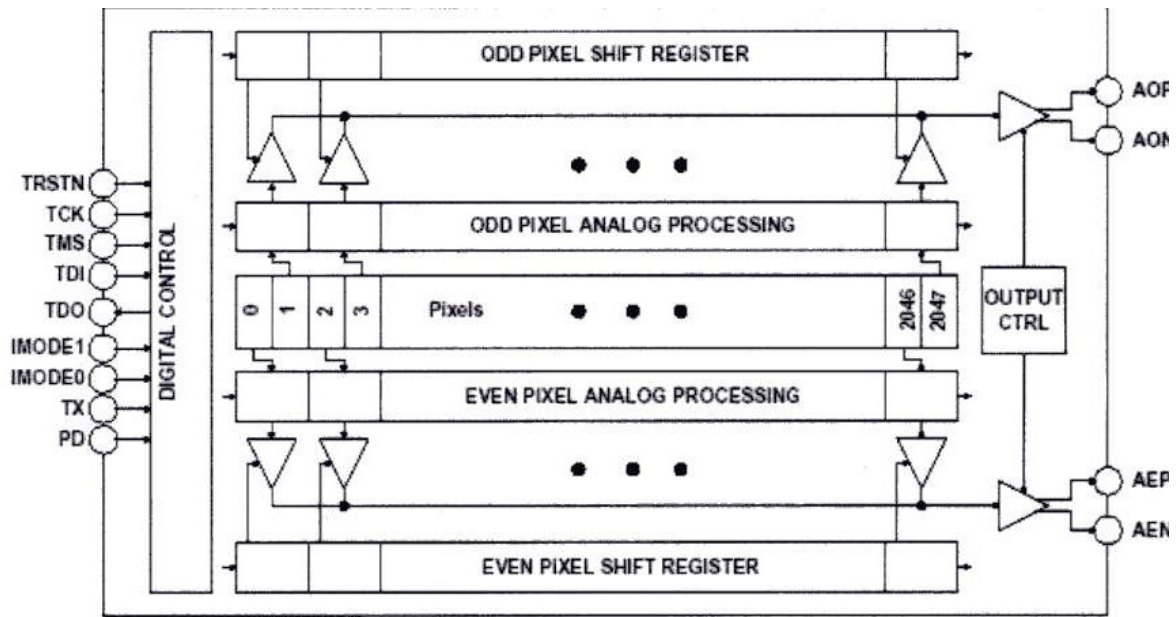

## SECTION 2

### Camera Hardware Interface

#### 2.1 Installation Overview

Before you integrate your camera into your system you should first determine some basic operating parameters such as what resolution you need. Do you know the speed of the object that your camera will be inspecting? One additional point you want to keep in mind is your lighting requirement.

One major item that you should identify early on in developing your system is the source of your EXSYNC control signal ( framegrabber, custom controller, shaft/web encoder, etc.).

#### 2.2 Connectors, Pinouts, and Cables

The CAM/CMOS-2K.LS uses one MDR-26 connector for CameraLink™ to communicate control signals, data signals, and serial communications.

CameraLink™ cables are available as a standard off-the-shelf-part, 3M #14X26-SZLB-XXX-OLC and others, so that detailed cabling work is unnecessary.

**Figure 2.2.1**  
**MDR-26 CameraLink™ Connector**  
**3M p/n 334 – 34 series**

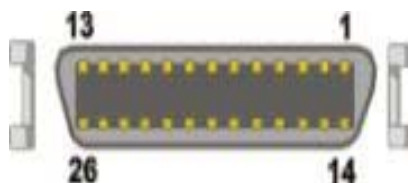

**Table 2.2.1**

Camera Pin #	Frame Grabber Pin #	Channel Link Signal
1	1	Inner shield
14	14	Inner shield
2	25	X0
15	12	X0+
3	24.0	X1-
16	11	X1+
4	23	X2-
17	10	X2+
5	22	Xclk
18	9	Xclk+
6	21	X3
19	8	X3+
7	20	SerTC+
20	7	SerTC-
8	19	SerTFG-
21	6	SerTFG+
9	18	CC1-
22	5	CC1+
10	17	CC2-
23	4	CC2+
11	16	CC3-
24	3	CC3+
12	15	CC4-
25	2	CC4+
13	13	Inner shield
26	26	Inner shield

**Notes:**

- Exterior overshield is connected to the shells of the connectors on both ends.
- 3M part 14X26-SZLB-XXX-0LC is a complete cable assembly, including connectors.
- Unused pairs should be terminated in 100 ohms at both ends of the cable.

**2.3 Power Supply**

- The camera uses a single voltage input, normally set to 5.0V.
- Ripple and noise is required to be < 20 mV RMS.
- Power is supplied through a Hirose connector.
- When installing the mating connector, be sure to line up the slots. This action will assure that you will not bend any of the pins.

**Table 2.3.1  
Hirose Receptacle**

Pin #	Description
1	+5.0 - +6.0 V DC
2	+5.0 – +6.0V DC
3	Ground
4	Ground



***If you are using an adjustable lab power supply it is extremely important that you apply the appropriate voltage to your camera. Incorrect voltage might damage the camera.***

**Figure 2.3.1  
Back View of CAM/CMOS – 2K.LS**



## 2.4 LED Indicator Status Lamp

**Table 2.4.1**

Light Color	Status
Green	Running
Blinking Amber/Red	Busy with command

## SECTION 3

# Camera Control

### 3.1 Quick Start with the Camera Link™ Interface

Follow your Frame Grabber manufacturer's instructions when inserting the frame grabber card into your PC. Be sure that you install the correct configuration software that matches the camera that you are using.

At this point your camera should already be connected to the DC power supply, and connected to the frame grabber in your PC. Your frame grabber will see our camera and start communicating almost immediately. As soon as your camera starts communicating with the frame grabber, you can verify this fact by looking at your monitor and observing the video signal.

To communicate with your camera we have created specific commands. In the next section we will go over these commands in detail.

### 3.2 Commands

Note: Commands are not case sensitive. To input commands, type in the three character command and hit enter.

#### Command Syntax:

**Command + enter, example:** Type in RSH, then enter

**Command + enter + value, example:** Type in SSM then enter, then type 2

**Command + enter + value + enter, example:** Type in SLR then enter, then type 2000, then enter

#### RSH

This command allows you to perform a hard camera reboot.

The camera returns.....Reboot Started

#### RSS

This command allows you to perform a logic reset.

No return.....no message

#### INQ

This command will show you what camera is connected to your PC.

The camera returns.....Fairchild Imaging 2K CMOS

## VER

This command will show you the current software version in your camera.

The camera returns.....FPGA REV.2.5 The current value may be different  
Micro rev. 0.90  
Prod rev. A 1.01

## SLR

This command allows you to set line rate, enter value and enter.

The range for line rate should be 204 – 38610.

## CPO

This command allows you to Calibrate Pixel Offset. You can observe this command by the blinking green/amber LED. When the LED stops blinking, that means that the calibration of the pixels is completed.

***You must cover lens when performing this operation!***

## CPG

This command allows you to Calibrate Pixel Gain. We strongly recommend that this command be done after each CPO. To perform this operation correctly the camera must look at a uniform illuminated light source. The LED will be a blinking amber/red.

## VOM

This command reads the different component voltages located within the camera.

The camera returns.....INPUT = 6.103  
3.9VD = 3.225  
3.4VS = 3.448  
1.5VD = 1.495  
1VAD2 = 0.980  
1VAD = 0.980

## TSB

This command reads the internal camera temperature.

The camera returns.....Temp 39.42°C (example)

## SIT

This command allows you to set the integration time.

Set line rate first (SLR) before using this command.

Enter value plus enter value in microseconds, Range is 20 – 4900.

## SSM

This command allows you to set the Sync mode. When selecting the option you need, enter the appropriate single digit number, and then hit enter.

	<u>Value</u>	<u>Function</u>
The camera returns .....	1	Free run
	2	External Sync
	3	External Sync, fixed integration
	4	External Sync, electronic shutter

## SCM

This command allows you to select a correction mode. When selecting the option you need, enter the appropriate single digit number and then hit enter.

	<u>Value</u>	<u>Function</u>
The camera returns.....	1	M1 (1 <sup>st</sup> memory)
	2	M2 (2 <sup>nd</sup> memory)
	3	Offset Correction
	4	Gain Correction
	5	No Correction
	6	Full Correction

## STP

This command allows you to select a test pattern. When selecting the option you need, enter the appropriate single digit number, and then hit enter.

	<u>Value</u>	<u>Function</u>
No output from camera.....	1	Horizontal Ramp
	2	Vertical Ramp
	3	Vertical Bars
	4	Vertical Ramp and Bars
	5	0
	6	4095
Other		Video

## CBR

This command allows you to change the Baud Rate. You will not see anything on your monitor.

Here is a table of stored rates in the camera...

<u>Value</u>	<u>Function</u>
1	9600
2	19200
3	38400 (Default)
4	57600
5	115200

If you can't resist changing the baud rate, select the appropriate single digit number and hit enter.



## LED

This command allows you to change the color. When selecting the option you need to, enter the appropriate single digit number and hit enter. Your screen will be blank during this command

You can input one of the following:

<u>Value</u>	<u>Function</u>
0	Amber
1	Green
2	Red
3	Off

## GDA

This command allows you to show all of the DACs (Digital to Analog Converter). When selecting the option you need, enter the appropriate single digit number and hit enter.

The camera returns...

3:Gain F_odd = 0.490V	8:GainF_even = 0.490V
2:GainC_odd = 0.235V	6:GainC_even = 0.235V
4:Offset_odd = 1.199V	7:Offset_even = 1.199
1:CML_odd = 1.425V	5:CML_even = 1.425

## SDN

This command allows you to select one of the above DAC numbers, and change its value.

Example: SDN + enter + 486 + enter                      enter value between 0 - 1023

## GDN

This command allows you to verify what you just did under the SDN command.

Example: you would input the following GDN + enter + 1

The camera returns a value between 0 - 1023

## SAP

Store in Flash both correction memories, all registers and DAC values.

	<u>Value</u>	<u>Function</u>
Store all parameters	0	Default factory calibrate
	1	User
	2	User

## RAP

Load from flash to camera. Recall all parameters.

<u>Value</u>	<u>Function</u>
0	Default factory calibration
1	User
2	User

## SBS

	<u>Value</u>	<u>Function</u>
Set bit shift	0	12 bit
	1	10 bit
	2	8 bit

## CAO

Adjust analog video offset mismatch. Calibrate analog offset 200 DN.

## SAG

Set analog gain 0 – 10 db

## CAG

Adjust analog video gain mismatch. Calibrate analog gain.

## GSN

Get camera serial number, returns 128 character string: serial number, model, etc.

## SGH

Set gain high. Set pixel gain in sensor.

## SGL

Set gain low. Set pixel gain in sensor.

## 3.3 Camera Command Summary

**Table 3.3.1**

<b>Command</b>	<b>Definition</b>	<b>Summary</b>
RSH	Reboot System Hard	Hard reboot of camera
RSS	Reset Command	Logic reset of camera
INQ	Inquiry	Shows what camera is used
VER	Version	Shows current software
SLR	Set Line Rate	This function allows line rate change
CPO	Calibrate Pixel Offset	This function performs correction of pixel offset
CPG	Calibrate Pixel gain	This function performs correction of pixel gain
VOM	Voltage monitoring	This function shows internal voltages
TSB	Temperature Sensor Board	This function shows temp. of sensor board
SIT	Set Integration Time	This function allows user to set integration time
SSM	Set Sync Mode	This function allows user to select sync mode
SCM	Select Correction Mode	This function allows user to select correction mode
STP	Select Test Pattern	This function allows user to select test pattern

Command	Definition	Summary
CBR	Change Baud rate	This function allows user to select baud rate
LED	Light Emitting Diode	Change LED state
GDA	Get DAC All	Returns current DAC setting as a voltage
SDN	Set DAC number	Change DAC (n) value
GDN	Get DAC number	Get DAC (n) value
SBS	Set Bit shift	This function allows user to shift 12, 10, 8 bit video
SAP	Stores all parameters	This function allows you to save default or user settings
RAP	Recalls all parameters	This function allows user to recall the factory calibration
GSN	Get serial number	This function allows user to retrieve camera info, e.g., model + camera serial number
CAO	Calibrate Analog Offset	This function allows user to calibrate the analog offset
CAG	Calibrate Analog Gain	This function allows user to calibrate the analog Gain
SAG	Set Analog Gain	This function allows user to set the analog gain
SGH	Set Gain High	Set Pixel gain in Sensor
SGL	Set Gain Low	Set Pixel gain in Sensor

### 3.4 The Four Modes for Synchronizing with the CAM/CMOS – 2K.LS

There are four synchronization modes as explained below and summarized in Table 3.4.1 below.

**Freerunning Mode** is described below in (Figure 3.4.2). In this mode, the camera is not triggered; instead it drives the world around it. It is the default mode set and shipped by the factory.

**ExSync Line Synchronization** is described below (Figure 3.4.3). The target asynchronously synchronizes the CAM/CMOS – 2K.LS from an external trigger via the ExSync line. The user selects ExSync Synchronization or any of the modes via the camera command set. In this mode, start of integration is asynchronously controllable with ExSync, and continues until the end of the line period.

**ExSync Line Synchronization with Programmable Integration Time** is described in (Figure 3.4.4). This mode is similar to ExSync Synchronization, but in addition, in this mode the user can program the duration of integration over the serial interface to be less than to the end of the line period.

**ExSync Line Synchronization with Electronic Shutter Control** is the fourth mode (Figure 3.4.5). It gives the user asynchronous hardware control both start and end of integration.

The control lines ExSync and ElectronicShutter are CameraLink™ lines CC1 and CC2 respectively as described in Reference A, and must be asserted by the frame grabber.

Table 3.4.1 Summary of CAM/CMOS-2K.LS Modes					
Mode	Synchronization	Line Start Trigger	Line End	Start of Integration	End of Integration
1 Free Running (factory default)	The CAM/CMOS 2K.LS drives the frame grabber(s).  Motion of the subject being imaged must be synchronized to the CAM/CMOS-2K.LS	The CAM/CMOS 2K.LS LineValid Camera Output Triggers the frame grabber(s) by Going High	Line Ends $t_{LinePeriod} - t_{XFR}$ after LineValid Camera Output Goes High  User may set $t_{LinePeriod}$ with Software	$t_{Initiation}$ + $t_{Reset}$ - $t_{XFR}$  after LineValid Camera Output Goes High	$t_{Integration}$  after start of Integration  User may set $t_{Integration}$ with Software
2 ExSync Synchronization	The User Synchronizes the CAM/CMOS-2K.LS via an Encoder.	The User Triggers the CAM/CMOS-2K.LS by taking ExSync Camera Input Low	When the User takes ExSync Camera Input Low Again	$t_{Reset}$ after the System takes the ExSync Camera Input High	When the User takes ExSync Camera Input Low
3 ExSync Synchronization with Programmable Integration Time			(In this way, the Line Rate is User-Set by Frequency of ExSync)		$t_{Integration} + t_{Reset}$ after User takes ExSync Camera Input High
4 ExSync Synchronization with Electronic Shutter Control			$t_{Reset}$ after the User takes ElectronicShutter Camera Input High	When the User takes the ElecShutter Camera Input Low	

**Figure 3.4.1 -- Mode 1: Freerunning**

...in this basic mode, usually used for diagnostics & debugging,  
no triggering is applied to the camera...

...instead, the camera drives the system with the LineValid Camera Output.

*The Line Period and Integration*

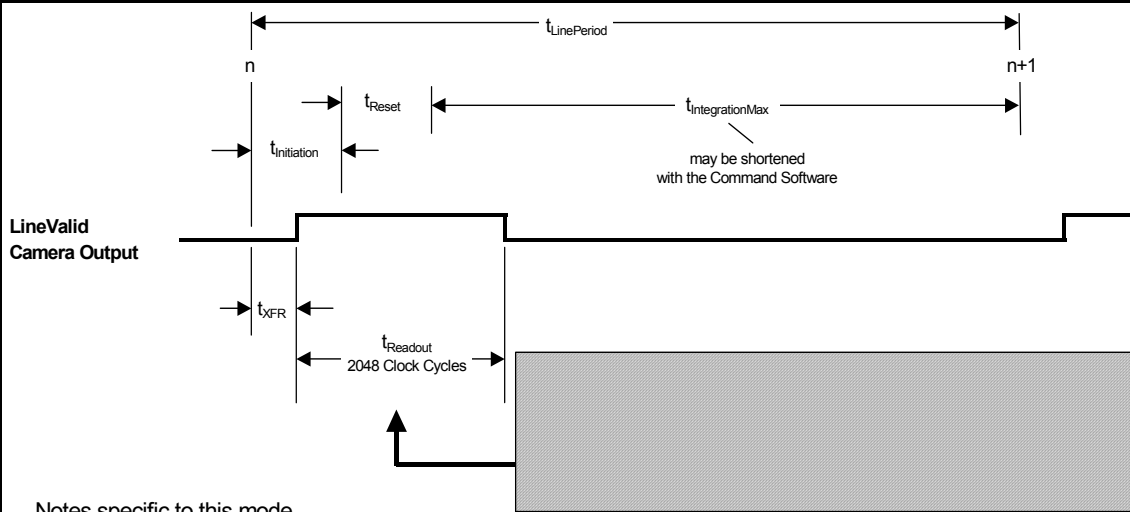

Notes specific to this mode

- 1 The camera is not triggered – instead, the camera itself synchronizes the system. This is the default mode set by the factory
- 2 The camera internally initiates readout of line "n" on its own. LineValid goes high a time " $t_{\text{XFR}}$ " afterwards
- 3 The user must synchronize motion of the material moving past the camera to the camera's LineValid output
- 4 The user must synchronize collection of data in the PC frame grabber to the LineValid camera output
- 5 While LineValid is high, data may be sampled on rising edges of Camera Strobe Output for the 2048 clock cycles of readout as shown in the inset above; this is the same for all four modes
- 6 A time " $t_{\text{Initiation}}$ " after the camera internally initiates the readout-and-integration cycle, the camera also internally initiates pixel reset; Integration then begins time " $t_{\text{Reset}}$ " later, with this integrated information to be read out in the subsequent line "n+1"
- 7 The factory-set default is for integration to run until the end of the line period, which results in a maximum integration time " $t_{\text{IntegrationMax}} = t_{\text{LinePeriod}} - t_{\text{Reset}} - t_{\text{Initiation}}$ ".
- 8 The line period " $t_{\text{LinePeriod}}$ " and the integration time " $t_{\text{Integration}}$ " are selected by the user with the Command Software

**Figure 3.4.2 -- Mode 2: ExSync Synchronization**

...gives the user asynchronous hardware control over initiation of the camera readout cycle and over termination of the line period...

...separately gives the user asynchronous hardware control

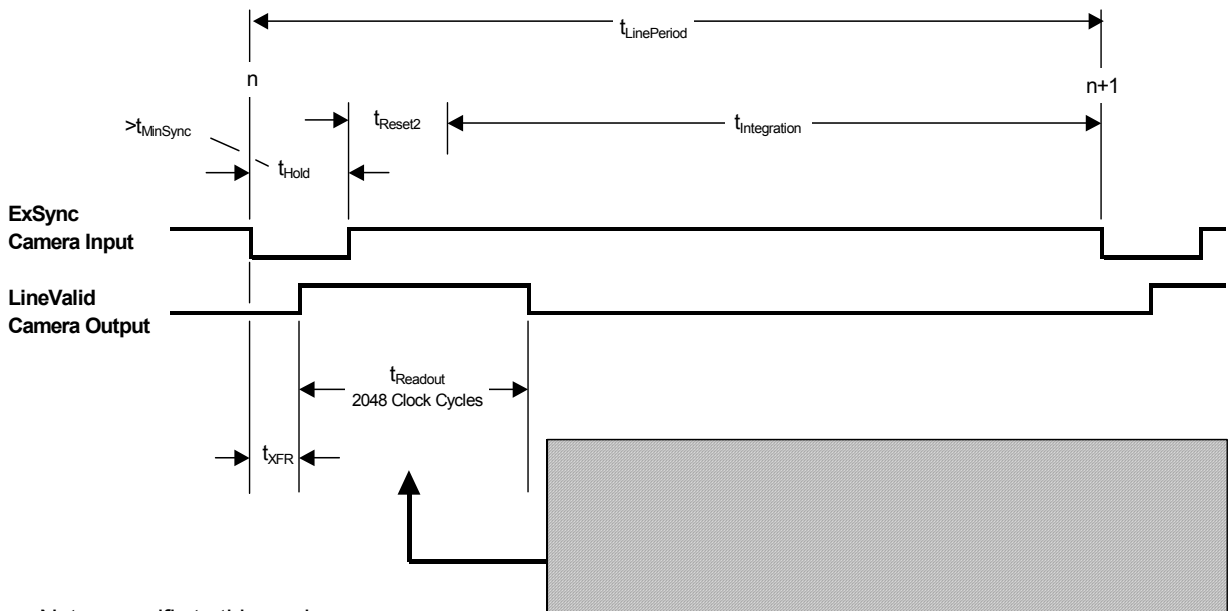

**Notes specific to this mode**

- 1 Unlike Freerunning mode, the user triggers (separately) both the CAM/CMOS - 2K.LS readout cycle, and the CAM/CMOS - 2K.LS reset-&-integration cycle. All of the modes other than Freerunning mode allow the user to do this
- 2 The user initiates a readout cycle by taking ExSync low as shown above. Readout actually begins a time " $t_{XFR}$ " after ExSync is taken low, and lasts 2048 clock cycles
- 3 The user can read data from the CAM/CMOS - 2K.LS while LineValid is high as shown above and explained in Figure 3.4.1
- 4 The reset-&-integration cycle to be read out in the next period "n+1" is initiated by ExSync returning high; integration begins when reset is complete a time " $t_{Reset}$ " after ExSync goes high, and continues for the remainder of " $t_{LinePeriod}$ ". The user can therefore shorten integration time by increasing " $t_{Hold}$ " above
- 5 The line period is set by the user by returning ExSync low, thereby initiating the next "n+1th" readout cycle
- 6 The minimum time that ExSync can be held low is " $t_{MinSync}$ " as shown above
- 7 Integration is cut off when the user takes ExSync low again as shown in the waveforms above
- 8 The line period must be greater than or equal to " $t_{Readout}$ " plus " $t_{XFR}$ ", which sets maximum line rate to 50K lines/sec
- 9 If the user brings the ExSync Camera Input low prior to " $t_{XFR}$ " + " $t_{Readout}$ " after ExSync goes low, then the CAM/CMOS 2K.LS delays initiation of the "n+1th" readout cycle until " $t_{Readout}$ " + " $t_{XFR}$ " has elapsed after ExSync last went low

**Figure 3.4.3 -- Mode 3: ExSync Synchronization with Programmable Integration Time**

...Mode 3 is similar to Mode 2...

...the differences are that the reset-&-integration cycle is initiated when ExSync is taken low...

...and the duration of integration

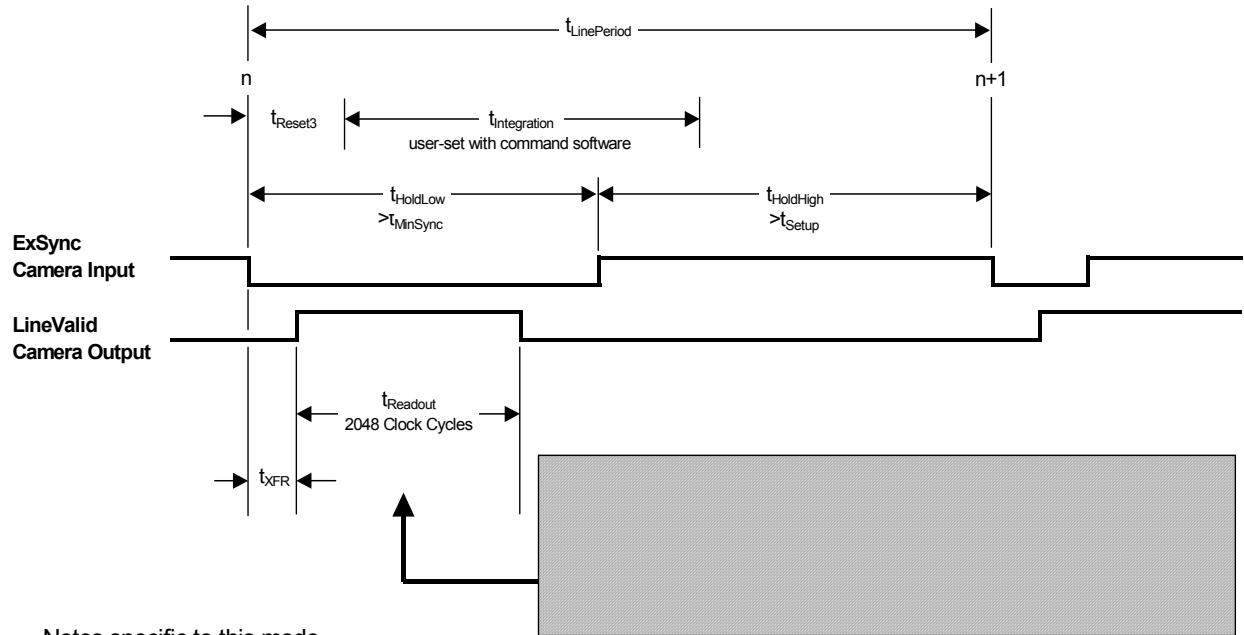

Notes specific to this mode

- 1 The reset-and-integration cycle is initiated by ExSync being taken low by the user; this has the effect of starting integration as soon as possible at the beginning of the line period
- 2 ExSync must be returned high at least " $t_{\text{Setup}}$ " prior to taking it low again to signal the end of the line period
- 3 The user sets integration time " $t_{\text{Integration}}$ " with the software command set
- 4 The user can read data from the CAM/CMOS - 2K.LS while LineValid is high as shown above.

**Figure 3.4.4 -- Mode 4: ExSync Synchronization and Electronic Shutter Control**

...this mode gives the user full asynchronous hardware control over start and end of integration with the "ElectShutter" Camera Input.

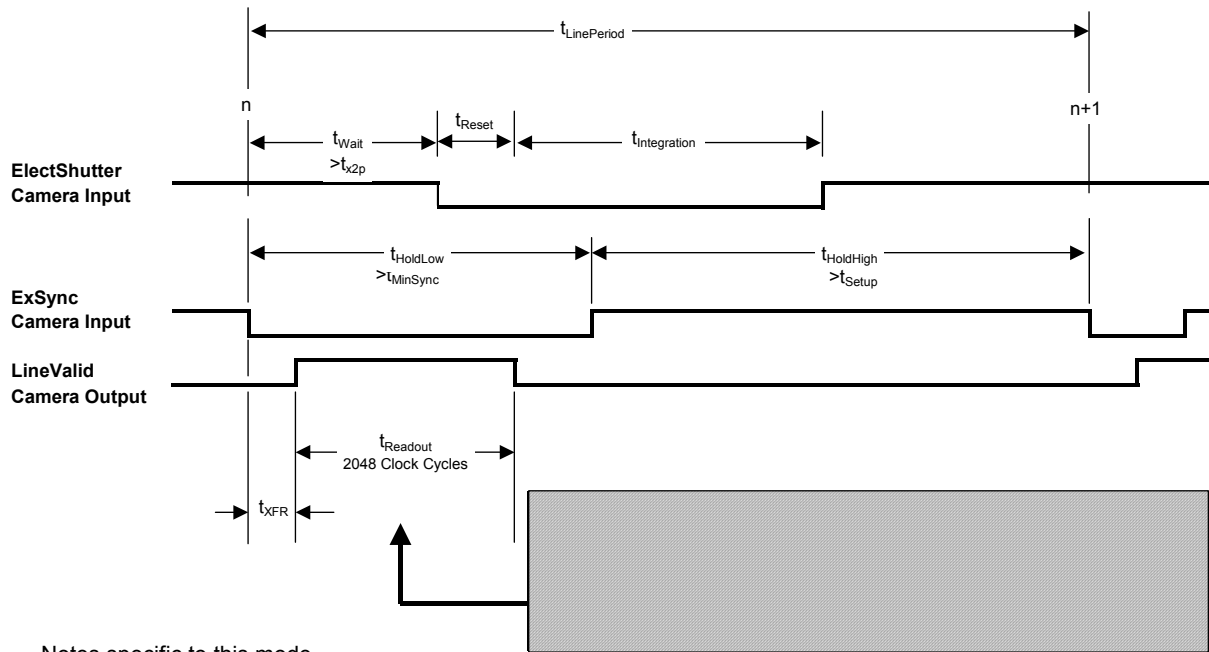

**Notes specific to this mode**

- 1 The user initiates the reset-&-integration cycle by taking the ElectShutter Camera Input high
- 2 The user terminates integration by taking the ElectShutter Camera Input low
- 3 ElectShutter will not be recognized by the camera until a time " $t_{x2p}$ " after ExSync is brought low
- 4 If ElectShutter is brought high earlier than constrained above, the camera will interpret this as ElectShutter going high " $t_{x2p}$ " after ExSync went high
- 5 Any software command setting integration time is overridden by ElectShutter Camera Input
- 6 If ElectShutter is still high when ExSync is taken low to initiate the next readout cycle, then integration is immediately terminated
- 7 The user can read data from the CAM/CMOS - 2K.LS while LineValid is high as shown above.



<b>Table 3.5.6 Synchronization Timing Values CAM/CMOS-2K.LS</b>	
$t_{XFR}$	300nsec
$t_{initiation}$	40nsec
$t_{Readout}$	25.6nsec
$t_{Reset2}$	4 $\mu$ sec
$t_{Reset3}$	5 $\mu$ sec
$t_{MinSynch}$	1.425 $\mu$ sec
$t_{Hold}$	1.425 $\mu$ sec
$t_{x2p}$	875ns

## SECTION 4

### Mechanical and Optical Guidance

Figure 4.1

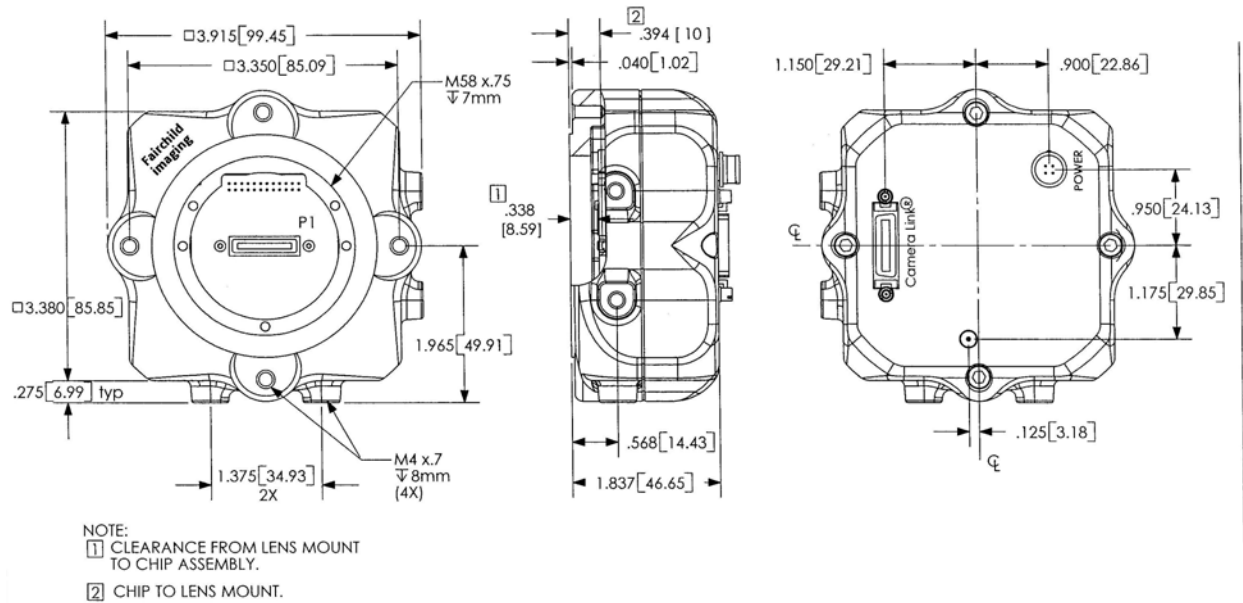

#### 4.1 Camera Dimensions and Mounting Facilities

The CAM/CMOS – 2K.LS camera housing is manufactured with high precision. Planar, parallel, and angular sides guarantee precise mounting with high repeatability.

The CAM/CMOS – 2K.LS is equipped with four M4 mounting holes on the front and two M4 mounting holes on one side and on the bottom of the camera.



**Use caution in the following ways to avoid stripping threads or stressing the case:**

- Use only M4 screws -- do not try other metric approximation size screws
- Do not over torque; do not over tighten screws beyond the depth of the holes; do not otherwise force screws or create a bending moment with them
- Use caution in crafting mounting brackets so that you do not interfere with the lens, or exert force on the lens extender tube barrel, or torque or otherwise place force on any of the connectors on the back of the case. A "L" mounting bracket (figure 4.4) is available; contact your Fairchild Imaging representative for more details.

## 4.2 Lensing

The CAM/CMOS – 2K.LS as shipped from the factory accepts universal manual "F" mount lenses that are available from a number of suppliers. The standard 0.050" Nikon mounting ring is shown in Figure 4.3 below.

Figure 4.3 below shows that the lens extender tube can be detached by unscrewing it so that an optional "C" mount can be installed. If you wish to do this, please contact your Fairchild Imaging Sales representative.

With the lens mount (lens extender tube and its lockring) removed, the front surface of the camera is seen as a square with a large threaded hole in the center. The "z" distance from the surface of the square to the top of the sensor is 13.72mm.

## 4.3 Lens Mount Extender Tube

Figure 4.3.1

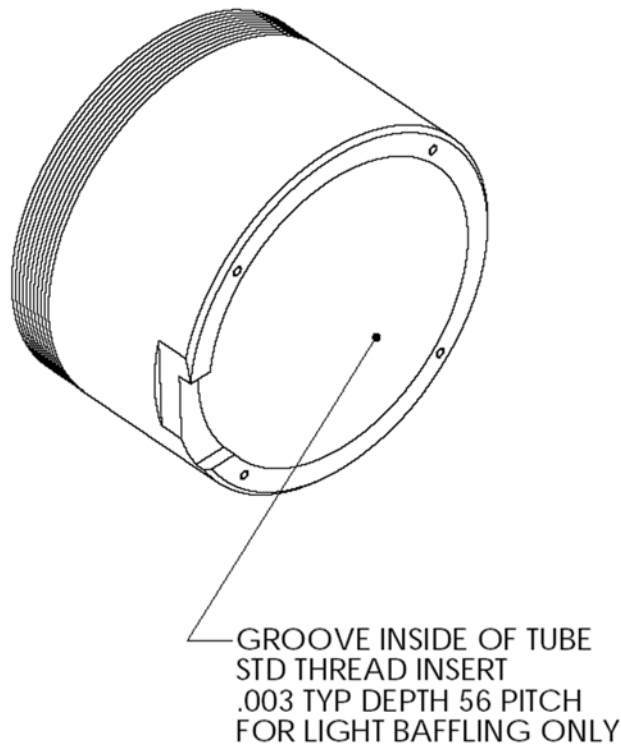
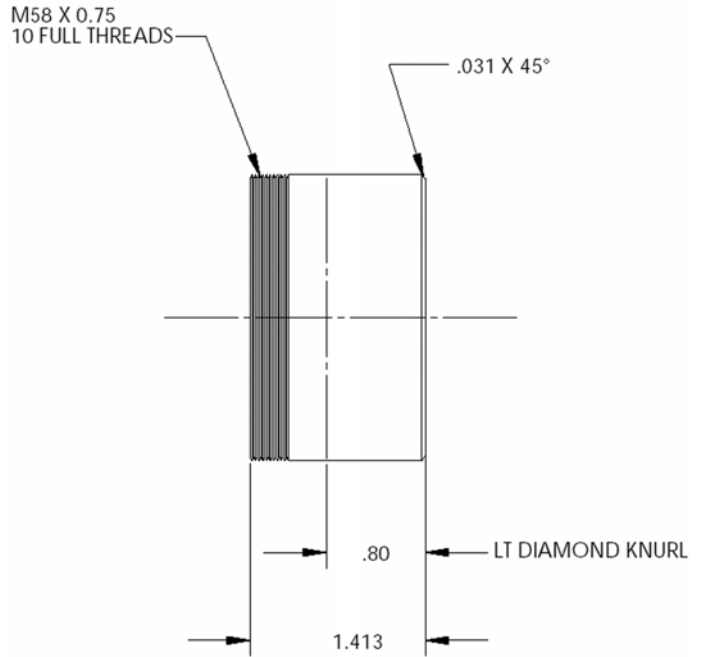
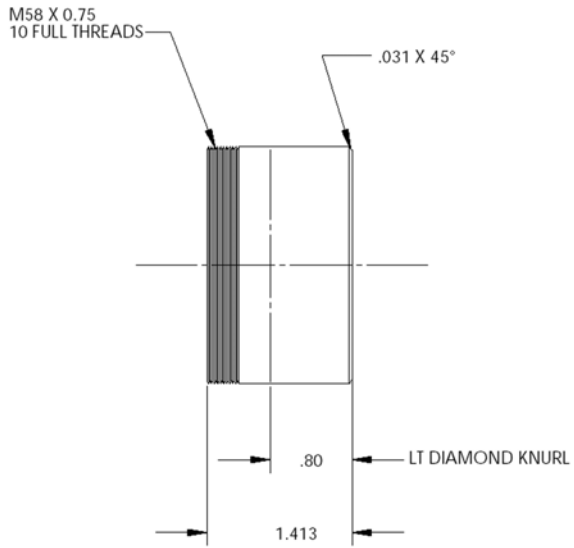

Figure 4.3.2



## 4.4 Mechanical Drawing of Available Camera Face Mounting "L" Bracket

Contact your Fairchild Imaging representative for more details

Figure 4.4.1

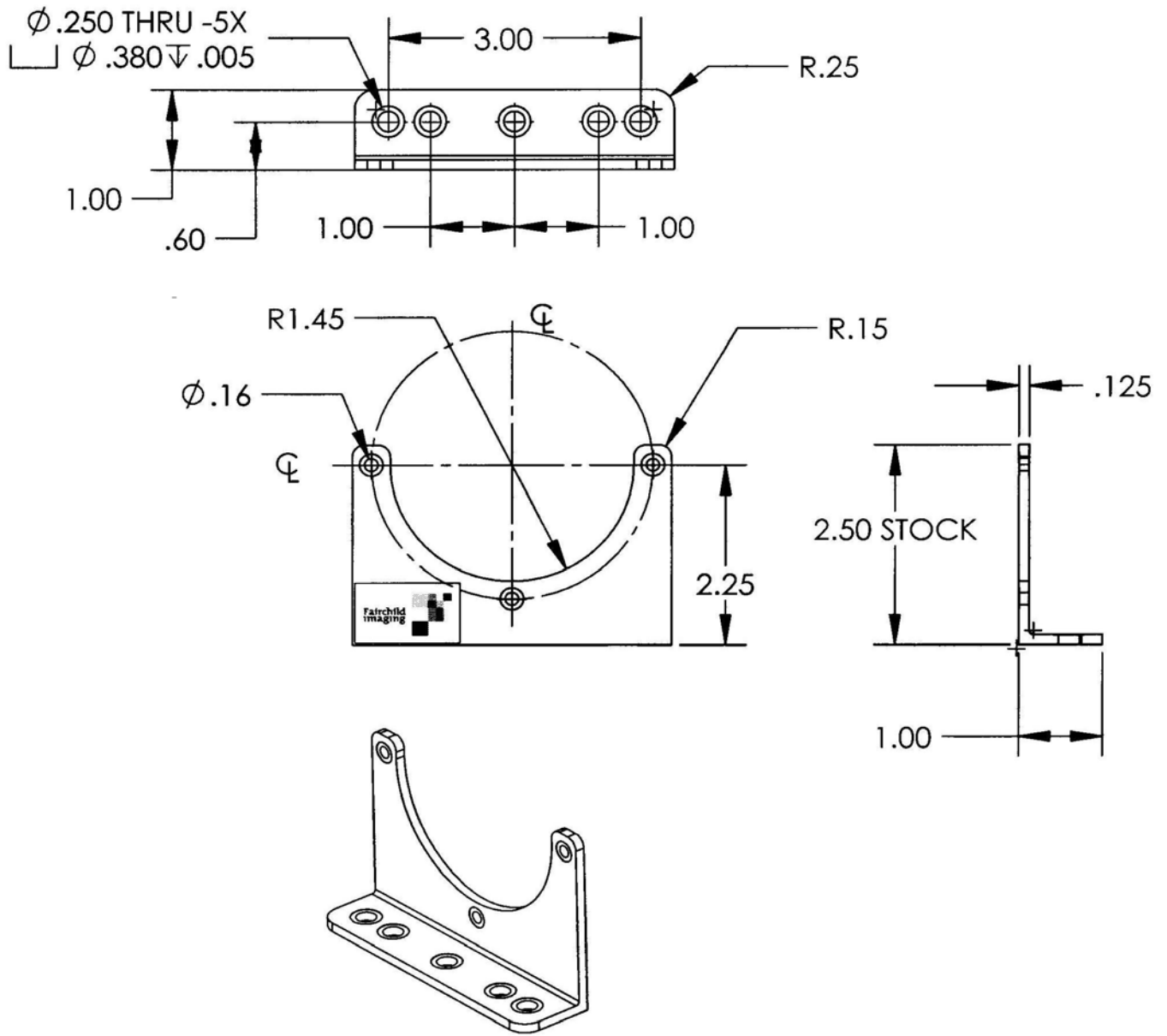

## 4.5 Lenses

Fairchild Imaging does not supply lenses.

## 4.6 Positioning Accuracy of the Sensor Chip in the Camera

Positioning accuracy of the sensor chip in the horizontal and vertical direction is + 0.2 mm. Rotational positioning accuracy is as shown. Reference position is the center of the camera housing.

Since the translatory and rotational positioning tolerance depend on each other, the worse case of maximum rotational and horizontal/vertical mis-positioning can not occur at the same time.

**Figure 4.6.1**

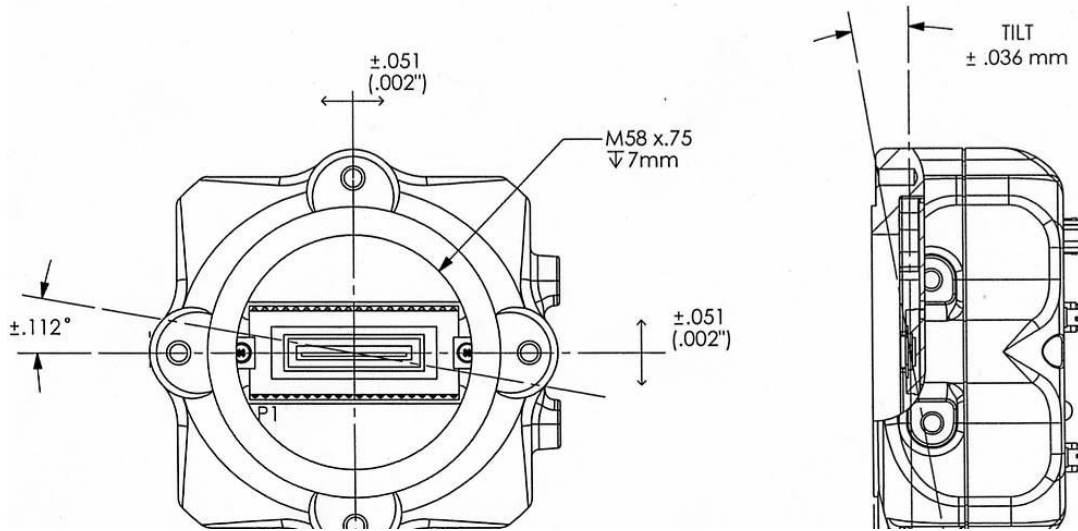

## 4.7 Illumination

In your application you must know the amount and wavelengths of light required. Some additional things you want to consider respective to illumination are the characteristics of your light source and the spectral characteristics and speed of the object(s) being inspected.

## 4.8 Light Sources

When selecting and setting up your light source you should be aware of the following.

- Light sources do age over time.
- When light sources age, they may produce less/more light in some areas of the spectrum.

## 4.9 Lens Modeling

Several camera companies have included this and like information in their manuals. For reference material it is very useful.

The **focal point** is the point at which the image of an infinitely distant object is brought to focus. The **effective focal length ( $f'$ )** is the distance from the second principal point to the second focal point. The **back focal length (BFL)** is the distance from the image side of the lens surface to the second focal point. **The object distance (OD)** is the distance from the first principal point to the object.

Figure 4.9.1

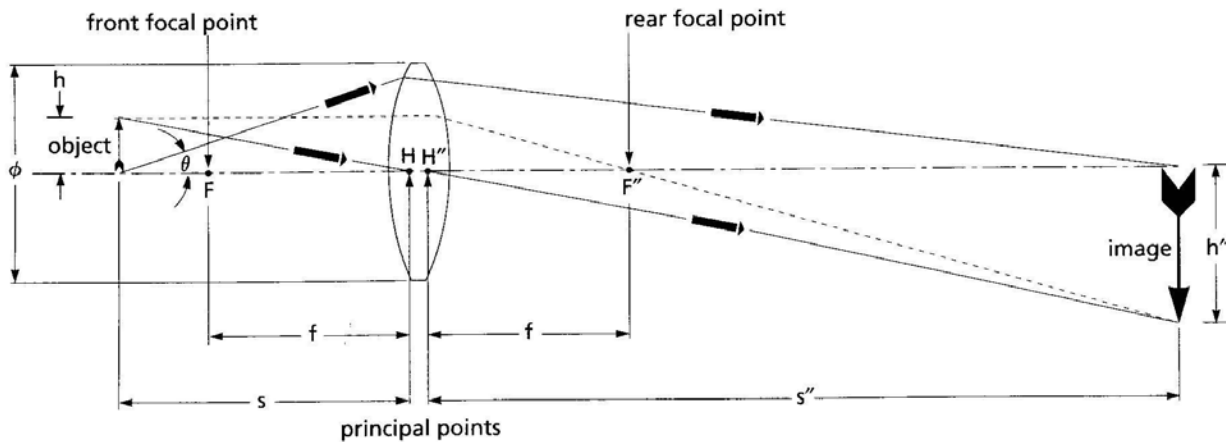

Note location of object and image relative to front and rear focal points.

## SECTION 5

### Handling Instructions

#### 5.1 Electrostatic Discharge

The Fairchild Imaging LNL2048S is a metal oxide semiconductor (MOS) device, and as all such devices, has some limited inherent susceptibility to electrostatic discharge (ESD).

All reasonable and customary design steps have been taken to provide ESD protection circuitry. The CMOS technology provides greater immunity to ESD problems than do CCD devices.

***Electrostatic charge placed at the sensor could cause charging of the chip which in some situations might not be readily dissipated and minor impact on performance might be temporarily experienced. Therefore, do not insert your finger or any other object into the lens mount barrel.***

#### 5.2 Preventing ESD Damage

***Please be certain to ground yourself prior to handling the camera.***

***Ensure that your working environment is grounded, including conductive floor mats.***

***Do not touch the window of the imager.***

#### 5.3 Protecting Against Dust, Oil and Scratches

***Be certain to avoid dust buildup on the sensor window, where it could block the optical path.***

By not touching the surface of the sensor, you avoid introducing oil and avoid scratching the sensor window. ***Again, you should not insert anything into the lens mount barrel.***

#### 5.4 Cleaning the Sensor Window

Use compressed air to blow off particulate.

If for some reason cleaning of the sensor window is required, use lens wiping cloth with a *small amount* of eyeglass cleaning fluid. ***Do not use solvent as it may smear the sensor window.***



## SECTION 6

# Troubleshooting

## 6.1 Check the Obvious Things Out First

When trouble shooting, you want to start the process with the obvious components contained within your system:

- Computer system: hardware & software
- Is the frame grabber plugged into the correct slot on the mother board
- Are all electrical connections secure
- Check to make sure that your light source is fully functional
- Make sure that the pin configurations for all of your cables are correct
- Make sure you have selected the correct lense for your camera

## 6.2 Use the Camera Control Interface to Perform Checks

In the Camera Control function, verify that the camera returns the control screen. Verify that you can set various operating parameters.

## 6.3 Other Areas You Should Check

### Contact Customer Support

Before you call for support, be sure to make a note of the camera settings and the frame grabber settings you are using. You should also have saved captured live images. Customer support will frequently request that you e-mail copies of these captured images. See Section 7.

### Connections

Double check the pin outs of your cable. Make sure that the connections to the back of the camera and to your PC are secure.

### Power Supply Voltage

Make sure and measure that you have 5.0 volts at the camera connector.

### Noisy Power Supply

Check your power supply voltage output(s). Check also the noise and ripple specification of your power supply and measure both at the power supply output.

## **Everything Seems To Be Working, But No Image**

Remove the cover from your PC and reset all the cards into the Mother board. Sometimes when you move your PC, cards inside the PC work themselves loose.

## **Data Clocking/Output Signals**

Verify the presence of all data clocking and output signals.

## **Horizontal Lines or Patterns in Output**

To eliminate this type of problem use a DC light source.

## **No Output Or Non Specification Output**

If your camera has no output or is putting out an unspecified signal unknown to you. Check the length of your cable. If it is unnecessarily too long, and is also not shielded, your cable most likely is picking up radiated noise and is inputting the noise into your camera.

## **Vertical Patterns in Output**

Sometimes you might see patterns in your output. Most likely these are caused by dirt on your lens or possibly contaminants on the sensor window. Clean both to remove all contaminants.

## **Images are too Bright or too Dark**

The causes to this problem should be obvious, but many times are overlooked. If your image that you have captured is too dark or light, then experiment with the lens aperture. Sometimes if you lengthen or shorten the exposure time this will effect your image.

Remember your camera control command “CPG”. This command allows you to either increase or decrease pixel gain, which can have a dramatic impact on your image.

Lastly, don't forget to check your lighting.

## **Images Look Noisy**

There are several things that can cause this condition. Remember our camera command “CPG”. Work with this command. Try increasing and decreasing pixel gain until you find the right setting.

Look for an increase in dark current. If the ambient temp. increases this will cause noise in the image.

Look at your light source. If your light source is AC instead of DC this will make the image look noisy. Also if the object you are inspecting has different surface textures this could produce an image that may look noisy.

## **Bits That Do Not Change Value**

If you see that data bits are not changing values, after you have changed them, then the first thing to check is that the camera is not saturated by preventing light from entering. Next, disconnect the Camera Link cable from the camera. Check the digital signals at the output of the camera, ensuring that the correct values and signals are present.

## SECTION 7

### Product Support

If after troubleshooting your camera, and you still have problems, collect the following data about your application and situation and call Fairchild Imaging Customer Support.

**Note:** You may want to photocopy this page to fax to Fairchild Imaging @ 408-735-7352

<b>Your Name</b>	
<b>Company name</b>	
<b>Your phone number</b>	
<b>Your Fax number</b>	
<b>Product Model Number</b> (e.g. CAM/CMOS – 2K.LS)	
<b>Camera serial number</b>	
<b>Detailed description of problem encountered</b>	Please attach description with as much detail as appropriate

**When calling Fairchild Imaging, 1-800-325-6975, ask for Customer Support.**

## REFERENCE A

### ***Camera Link™ Introduction***

#### **Camera Link is a Protocol that is Implemented in Channel Link Hardware**

Camera Link is a communication interface for machine vision. The interface extends the underlying technology of Channel Link to provide a specification more useful in this application.

For years, the scientific and industrial digital video market has lacked a standard method of communication. Both frame grabbers and camera manufacturers developed products with different connectors, making cable production difficult for manufacturers and very confusing for consumers. A connectivity standard between digital cameras and frame grabbers has been long overdue and will become even more necessary as data rates continue to increase.

Increasingly, diverse cameras and advanced signal and data transmissions have made a connectivity standard like Camera Link a necessity. The Camera Link interface will reduce support time, as well as the cost of that support. The standard cable will be able to handle the increased signal speeds, and the cable assembly will allow customers to reduce their costs through volume pricing.

#### **Channel Link is a Widely-Used Signaling Method**

National Semiconductor initially developed the Channel Link technology for flat-panel displays, and based it on the LVDS physical layer. This technology was then extended for general-purpose data transmission. Channel Link is built up of sets of driver and receiver pairs. Each driver set accepts 28 single-ended data signals and an accompanying single-ended clock. This data is serialized 7:1, and the resulting four data streams and clock signal are driven over five LVDS pairs. The receiver accepts these five signals and drives the full 28 bits and clock signal to its output pins as shown in Figure A.1.

Channel Link's transmission method requires fewer conductors to transfer data and allow for a smaller connector, which is important for compact cameras such as the CAM/CMOS – 2K.LS

The Channel Link chipset provides data transmission rates up to 2.38 Gbit/sec.

#### **Channel Link uses LVDS, a Low-Voltage Differential Signaling Standard**

Low Voltage Differential Signaling (LVDS) is a high-speed, low-power general purpose interface standard. The standard, known as ANSI/TIA/EIA-644, was approved in March 1996. LVDS uses differential signaling, with a nominal signal swing of 350mV differential. The low signal swing decreases rise and fall times to achieve a theoretical maximum transmission rate of 1.923 Gbps into a lossless medium. The low signal swing also means that the standard is not dependent on a particular supply voltage. LVDS uses current-mode drivers, which limit power consumption. The differential signals are immune to up to  $\pm 1$  V common volt noise.

## Video Data Signals

The Channel Link technology is integral to the transmission of video data. Image data and image enable signals are transmitted on the Channel Link bus. Four enable signals are:

FVAL-Frame Valid (FVAL) is defined HIGH for valid lines	(not used by the CAM/CMOS – 2K.LS).
LVAL-Line Valid (LVAL) is defined HIGH for valid pixels CAM	(LineValid Output in the CMOS – 2K.LS).
DVAL-Data Valid (DVAL) is defined HIGH when data is valid	(Always High in the CAM/CMOS – 2K.LS).
Spare- A spare has been defined for future use	(not used by the CAM/CMOS– 2K.LS).

In the general specification, all four enable signals must be provided by the camera on each Channel Link chip. All unused data bits must be tied to a known value by the camera.

For more information on image data bit allocations, refer to the official CameraLink™ specification (<http://www.machinevisiononline.org>).

## Camera Control Signals

Four LVDS pairs are reserved for general-purpose camera control. They are defined as camera inputs and frame grabber outputs. Camera manufacturers can define these signals to meet their needs for a particular product. In the case of the Fairchild Imaging CAM/CMOS - 2K.LS, the signals are:

- "ExSync" Line Synchronization Input (generically Camera Control 1, CC1)
- "ElectShutter" Exposure Control Input (generically Camera Control 2, CC2)
- Spare, unused (generically Camera Control 3 ,CC3)
- Spare, unused (generically Camera Control 4, CC4)

## Communication

Two LVDS pairs have been allocated for asynchronous serial communication to and from the camera and frame grabber. Cameras and frame grabbers should support at least 9600 baud. These signals are:

SerTFG	Differential pair serial communications to the frame grabber.
SerTC	Differential pair serial communications to the camera.

The serial interface will have the following characteristics: one start bit, one stop bit, no parity, and no handshaking. It is recommended that frame grabber manufacturers supply both a user interface and a software application programming interface (API) for using the asynchronous serial communication port. The user interface will consist of a terminal program with minimal capabilities of sending and receiving a character string and sending a file of bytes. The software API will provide functions to enumerate boards and send or receive a character string.

## **Power**

Per the standard, power is not provided on the CameraLink™ connector of the camera. Power is supplied through the Hirose connector.

## **Port Assignments**

See Tables 3.4.1 for the options of using the CAM/CMOS - 2K.LS with CameraLink™.

In CameraLink™, a port is defined as an 8-bit word as shown in Figure A.2. The least significant bit (LSB) is bit 0 and the most significant bit (MSB) is bit 7. The full configuration CameraLink™ utilizes eight ports, "A" through "H," although the CAM/CMOS - 2K.LS Model Camera only requires three, again as shown in Figure A.2.

## **For More Information on CameraLink™**

Refer to the Automated Imaging Association's website at:

<http://www.machinevisiononline.org>

## Camera Link Connections -- the MDR 26-Pin Connector

The 3M MDR-26 connector was selected for its robust design and reputation for success with high-frequency Channel Link transfer rates over several years of experience.

The MDR-26 connector is addressed in Section 2.2

**Figure A.1**  
**Channel Link Operation**

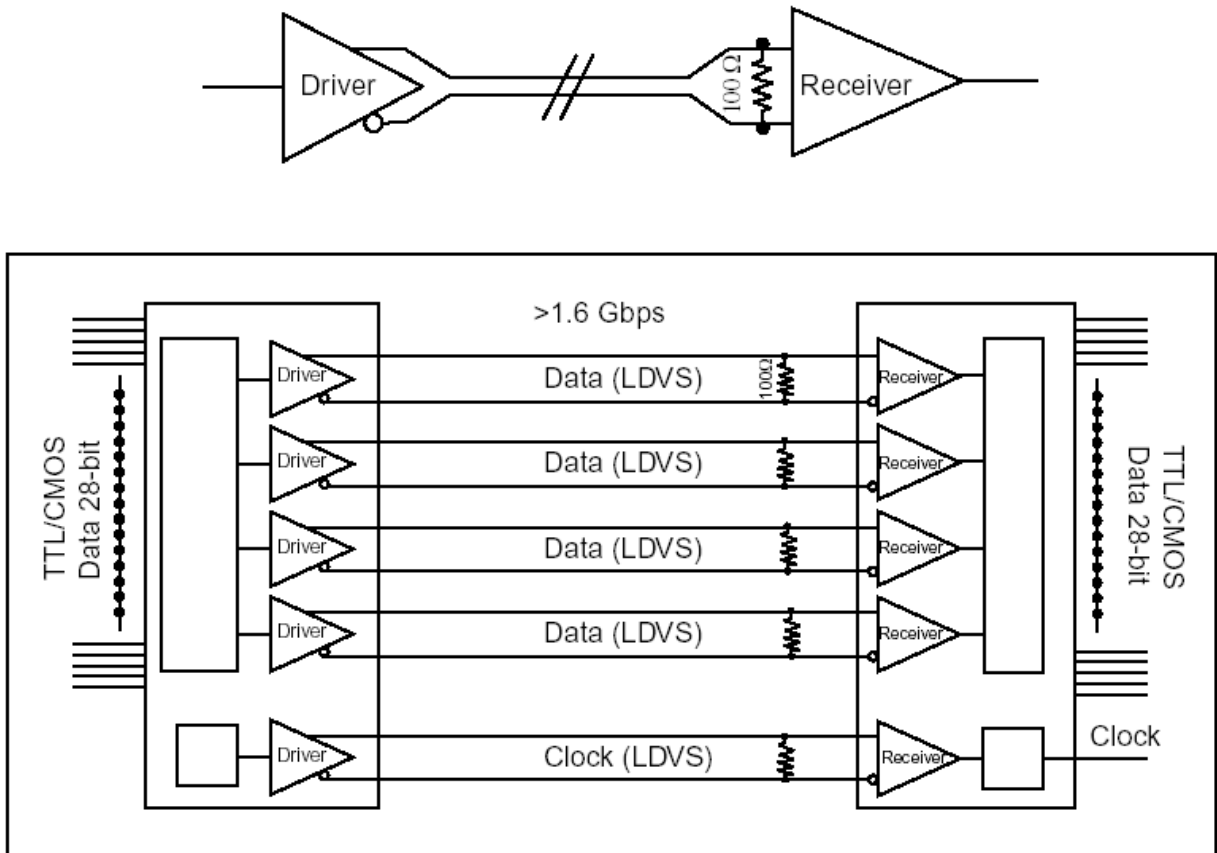

**Figure A.2**  
**Data Routing for Base, Medium and Full Configurations**

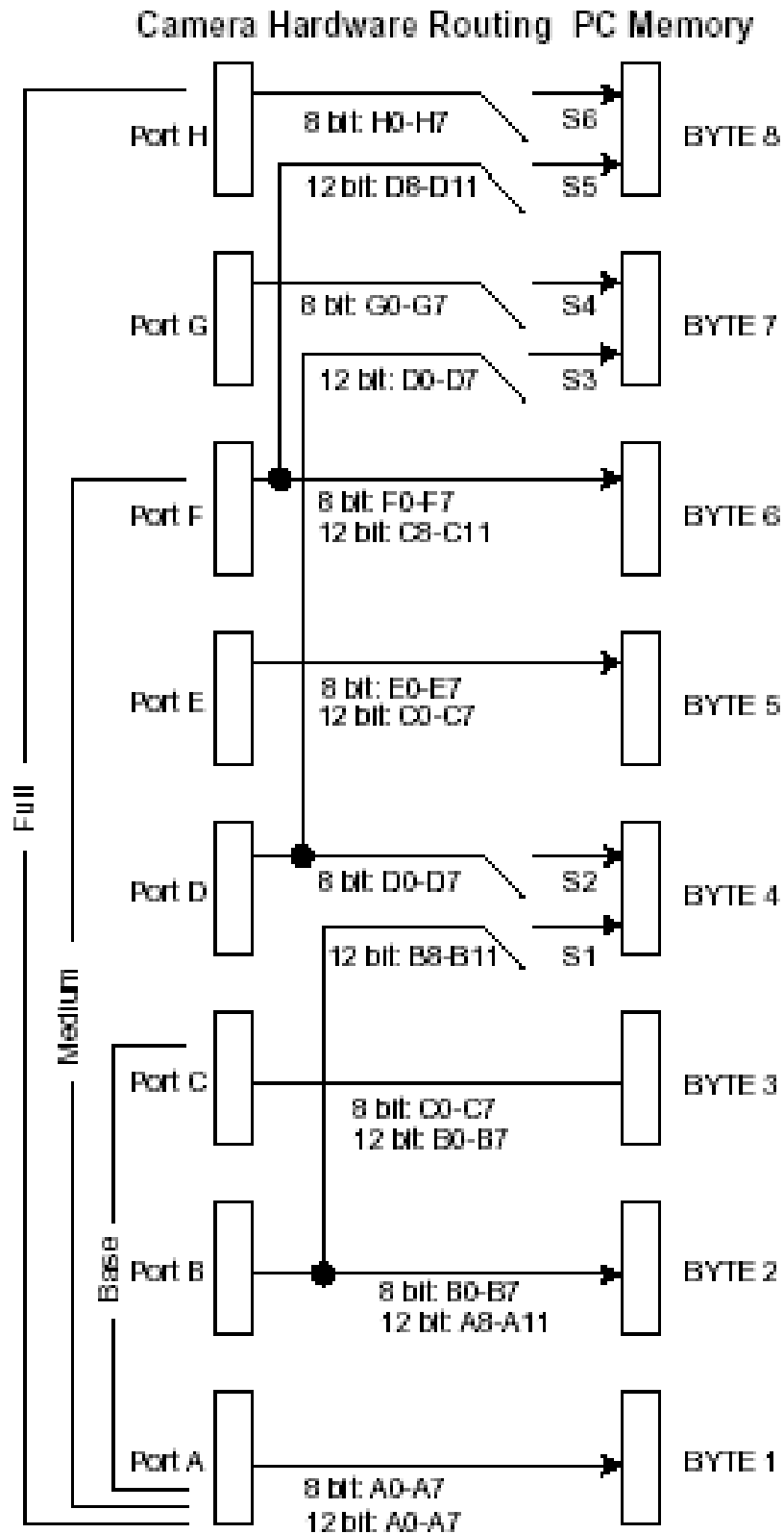
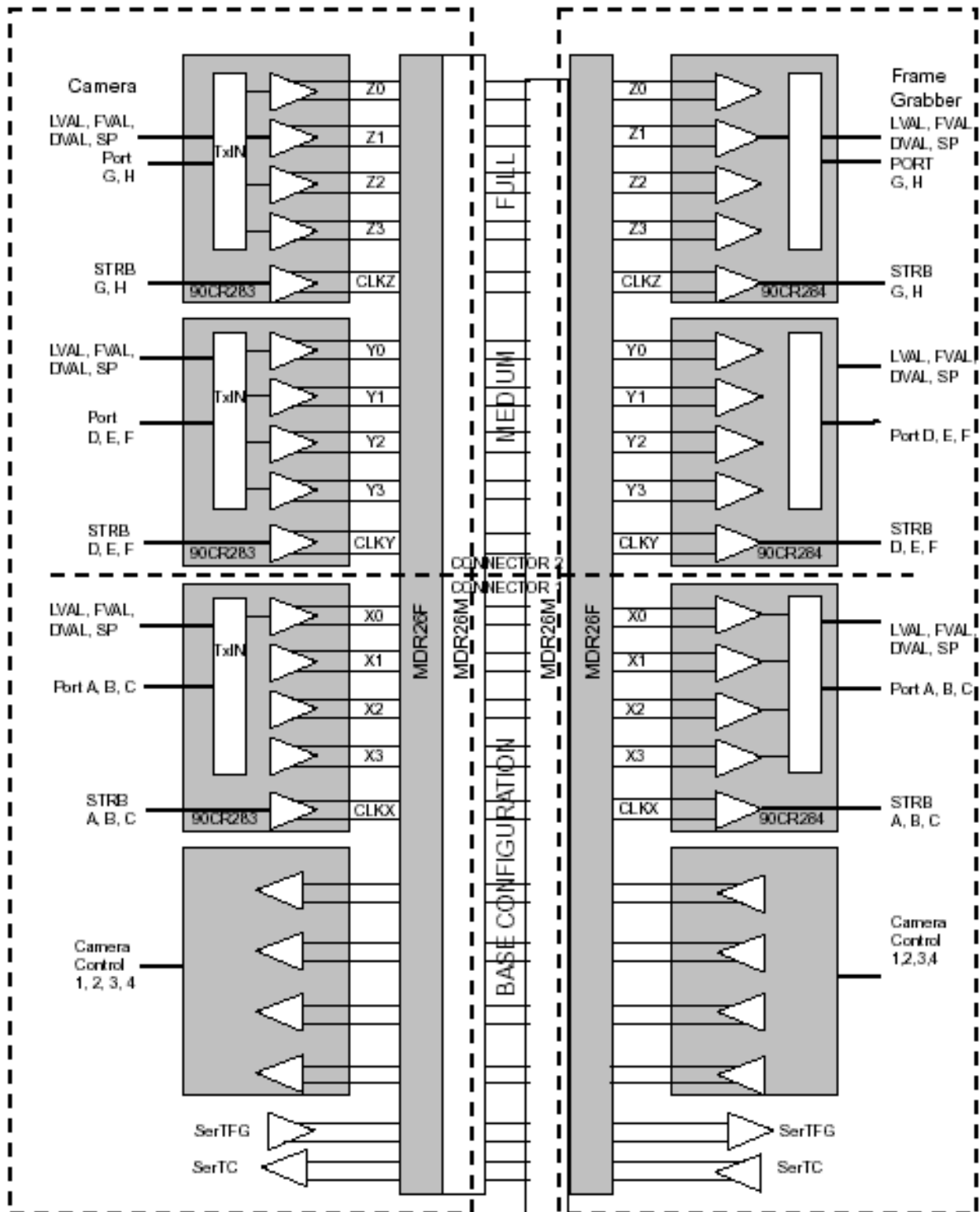

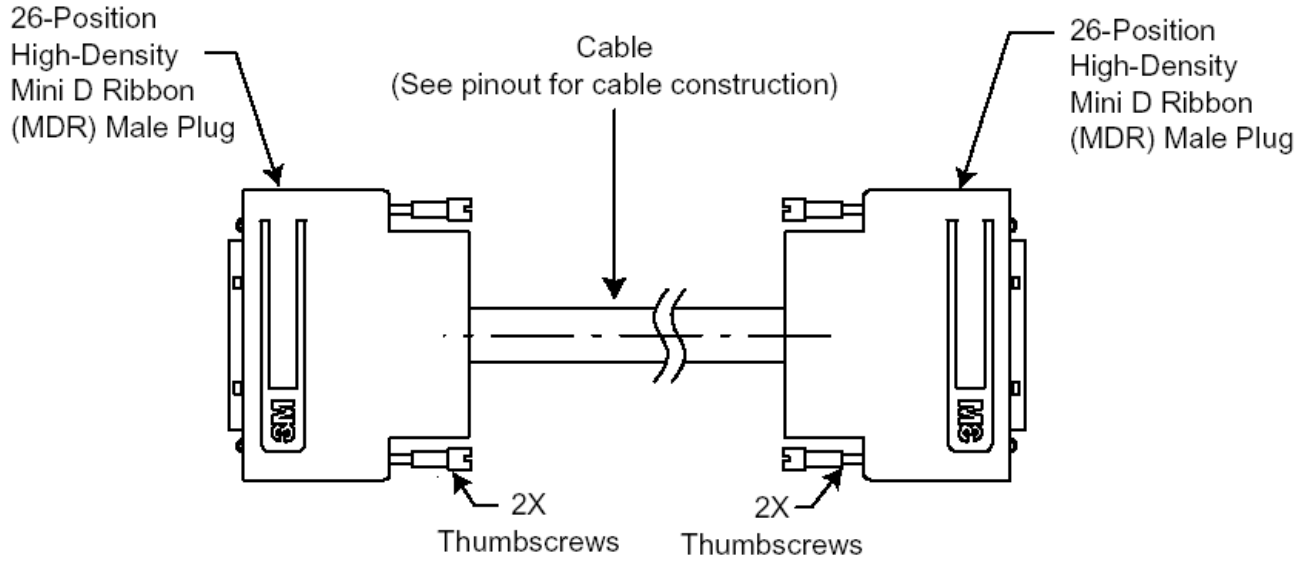

Figure A.3

Data Routing for Base, Medium and Full configurations



**Figure A.4**  
**Camera Link Cable**



**Figure A.5**  
**3M Part Number Ordering Information**  
(see further [www.3M.com](http://www.3M.com))

